

LA-UR-18-27677

Approved for public release; distribution is unlimited.

Title: Water Quality for High Performance Computing

Author(s): Bennett, William Ira

Intended for: Report

Issued: 2018-08-10

Disclaimer:

Los Alamos National Laboratory, an affirmative action/equal opportunity employer, is operated by the Los Alamos National Security, LLC for the National Nuclear Security Administration of the U.S. Department of Energy under contract DE-AC52-06NA25396. By approving this article, the publisher recognizes that the U.S. Government retains nonexclusive, royalty-free license to publish or reproduce the published form of this contribution, or to allow others to do so, for U.S. Government purposes. Los Alamos National Laboratory requests that the publisher identify this article as work performed under the auspices of the U.S. Department of Energy. Los Alamos National Laboratory strongly supports academic freedom and a researcher's right to publish; as an institution, however, the Laboratory does not endorse the viewpoint of a publication or guarantee its technical correctness.

2018

Water Quality for High Performance Computing

WATER TREATMENT FEASIBILITY STUDY
WILLIAM IRA BENNETT

LOS ALAMOS NATIONAL LAB | New Mexico 87545

Table of Contents

ABSTRACT.....	2
ABBREVIATIONS AND ACRONYMS.....	2
WATER TREATMENT TECHNOLOGIES.....	3
Coagulation/Flocculation.....	3
Chemical Coagulation.....	3
Electrocoagulation.....	4
Ion Exchange.....	5
Reverse Osmosis.....	5
SANITARY EFFLUENT RECOVERY FACILITY.....	7
WATER QUALITY NEEDS.....	10
Treatment Options.....	11
Option 1: Replicate SERF with design modification.....	11
Option 2: Replace chemical pre-treatment process with an alternative pre-treatment.....	13
Option 3: Remove pre-treatment.....	14
Estimated Cost.....	15
RECOMMENDED COURSE OF ACTION.....	18
Appendix.....	19
Appendix A: SWWS Effluent Water Quality Data.....	20
Appendix B: County Water Quality Data.....	23
Appendix C: Case Study- City of Longview, WA.....	24
Appendix D: Electrocoagulation Vendor Contact.....	31

ABSTRACT

To support future generations of high performance computers, the Advanced Simulation and Computing Program has a mission need for 80MW of peak power and cooling. Currently the water for the cooling towers at the Strategic Computing Complex (SCC) are cooled by the LANL waste water treated Sanitary Effluent Recovery Facility (SERF) or potable water from the county. The SCC cooling towers currently operate by cycling water between 2-3 cycles of concentration (COC), which is less than the ideal 6 cycles for maximizing water usage. SERF is the ideal water supplier, however when it's not available potable water is used. The amount of water that the SCC needs nominally is around 45 Million-Gallons/Year (MGY). The future super computer infrastructure (FSI) will need around 125 MGY nominally. SERF is approaching its production limit for reclaimed water. In order to avoid using 100% potable water for the FSI, the option of using non-potable reuse water from Los Alamos County (LAC) was analyzed.

This project scope is to focus on the water quality needed for the new super computer cooling towers. Once water quality needs are established, the ideal treatment process needs to be determined. Due to high silica content in water at Los Alamos, emphasis has been placed on treatment processes to remove silica. SERF's current and future ability to treat water was assessed, as well as the cost of running a SERF like facility or alternative.

ABBREVIATIONS AND ACRONYMS

HPC	High Performance Computing
SERF	Sanitary Effluent Recovery Facility
SCC	Strategic Computing Complex
MW	Mega-Watt
MGY	Million-Gallons/Year
GPM	Gallons per Minute
FSI	Future Super-computer Infrastructure
LAC	Los Alamos County
LANL	Los Alamos National Lab
PCB	Poly-Chlorinated Biphenyl
PO ₄	Phosphate
Fe	Iron
Ca	Calcium
Mg	Magnesium
TDS	Total Dissolved Solids
RO	Reverse Osmosis
EC	Electrocoagulation
COC	Cycles of Concentration
PPM	Parts per Million

WATER TREATMENT TECHNOLOGIES

Coagulation/Flocculation

Chemical Coagulation

Chemical coagulation involves the addition of chemicals to a batch or continuous stream of water to alter the physical state of Total Dissolved Solids (TDS) and contaminants dissolved within the water. During the coagulation process, TDS react with the added chemicals to create what is known as a floc or sludge as shown in Figure 1 below. Floc or sludge is the conglomeration of TDS and other water contaminants that group together, and precipitate out of solution. Chemical coagulation can proceed through either using organic or inorganic chemicals to facilitate the coagulation process. Organic coagulants are polymers with high positive cationic charge that destabilize the negative charge of particles in solution. The repulsion force present between the particles is minimized when the particles are destabilized, thus allowing the particles to conglomerate and form larger particles. The increasing size of the particles becomes the floc which eventually precipitates out of solution. The most commonly used reagents used in an organic chemical coagulation process are Polyamines, Polydadmac, Dicyandiamide resins, and Melamine-formaldehyde. Inorganic coagulation proceeds through a process known as a 'sweep-floc' mechanism. As the chemicals fall/flow through a solution they absorb the impurities within the solution, creating the floc. The most common reagents for inorganic chemical coagulation are Aluminum Sulfate, Aluminum Chloride, Polyaluminum Chloride, Ferric Sulfate, and Ferric Chloride.

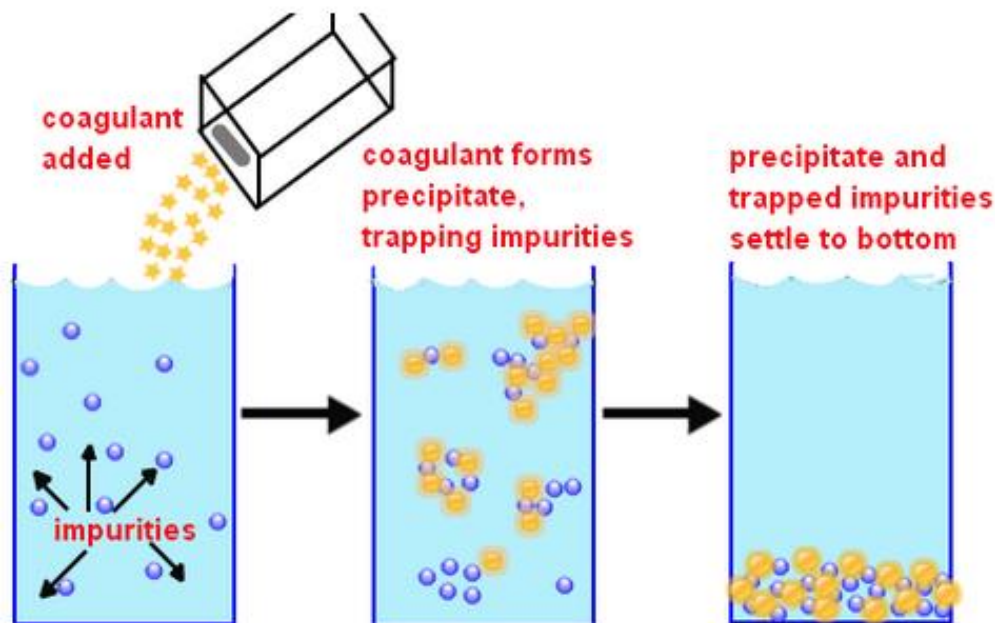

Figure 1: Graphic illustration of the chemical coagulation process

Electrocoagulation

Electrocoagulation (EC) works on the same principal as chemical coagulation. The general idea is still to introduce a chemical reagent into the solution that will destabilize the dissolved particles, causing them to aggregate and precipitate out of solution. Instead of adding chemicals or polymers directly into the solution, an electrocoagulation process required the use of electrodes and electricity. During this process water flows across the cathode and anode electrodes, while a current is passed through the electrodes. As the current is sent from the cathode to the anode, electrons travel across the water median. As the electrons travel through the water, they destabilize the particles within water, aiding in their precipitation out of solution. During this process the anode, which is referred to as the sacrificial anode, releases positively charge metal cations. Similarly to the most commonly used chemicals for chemical coagulation, the most common anodes for electrocoagulation are Iron (Ferric) and Aluminum. At the cathode end, water is broken into hydrogen gas (H_2) as well as negatively charged hydroxide anions (OH^-). A series of chemical reactions then occur between the introduced metal cations and the hydroxide anions. During which particles and other constituents within the water are either adsorbed or are a part of the chemical reaction to form a floc and precipitate out of solution as shown below in Figure 2. The H_2 gas formed at the cathode can be utilized to aid in the separation process as it can carry the generated floc to the top of the reactor vessel.

As mentioned above the anode is sacrificial, meaning that overtime it corrodes away and is consumed in the process. This is due to the solid metal electrode being converted into metal cations. Therefore the anode electrode will require constant replacement in order to continue the electrocoagulation process. Another concern with electrocoagulation is the passivation associated with the use of the electrode. Over time an oxide film develops on the cathode and the metal anode is being spent to facilitate the reaction. This results in an efficiency decrease due to less metal ions being emitted, as well as an increased difficulty passing a current through water.

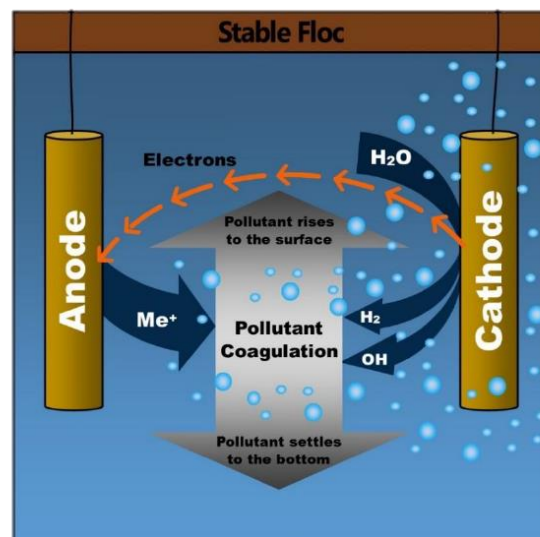

Figure 2: Graphic illustration of the electrocoagulation process

Ion Exchange

Ion exchange substitutes an undesirable constituent within water with another constituent that isn't of concern. The exchange of constituents occurs on an exchange resin, which is an insoluble matrix of porous microbeads. Resins can range from strongly acidic to strongly basic, depending on the need for negatively charged anion or positively charged cation exchange of ions. As water passes through the resin, the charged impurities within the water interact with the ions on the surface of the resin. The charged impurities displace the ions along the surface taking their place, thus being removed from solution by bonding to the microbeads. For the substitution to occur the ions on the microbeads being displaced must have the same charge as the impurities taking their place, however the magnitude of their charge doesn't need to be the same as shown in Figure 3 below. Therefore ion exchange is designed to removed charged/ion impurities from water, but not dissolved solid or neutral impurities.

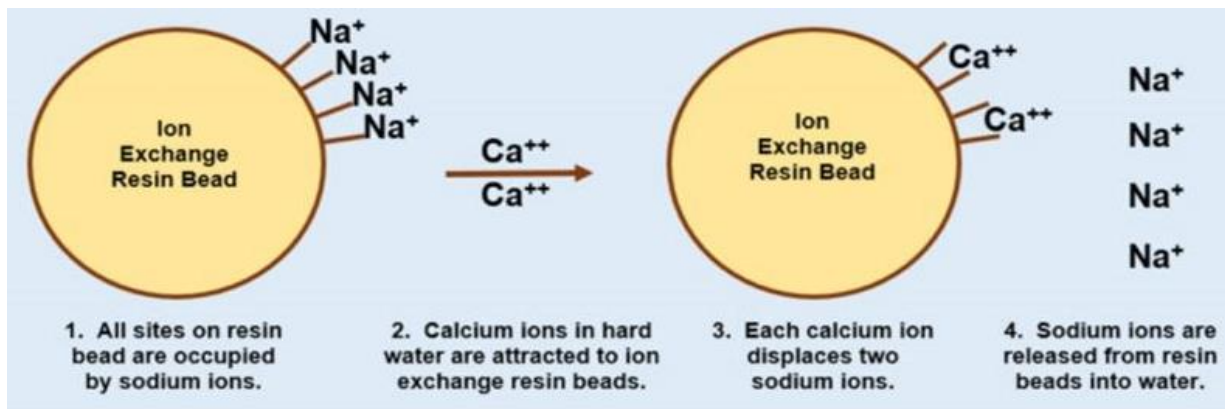

Figure 3: Graphic illustration of the Ion exchange process

Ion exchange does require continual replacement or recharging of the spent resin microbeads. The microbeads can only hold a finite amount of charged ions. Once all the initial ions bonded to the microbeads are substituted with the charged impurities within the water, the resin will cease to filter the water of impurities. In addition to this heavy metals and solids can foul the resin, by clogging the pores. Thus preventing the amount of water that can flow through an ion exchange system. Ion exchange resin also doesn't filter or remove microorganism from water. Leading to bacterial growth, as accumulated organic matter trapped within the resin can be used as a nutrient source.

Reverse Osmosis

Reverse osmosis (RO) is a process by which a solvent passes through a semipermeable membrane, producing a stream of clean water and a stream of waste water. The waste water stream contains the original feed's ions, large particles, and other contaminants. Through natural normal osmosis, water would flow from an area of low solute concentration to an area of high solute concentration. Diluting water highly concentrated in contaminants and ions, until the system approaches a state of equilibrium. In a RO unit, pressure is applied to the inlet stream of water to overcome the natural osmotic pressure difference between the two sides

of the semipermeable membrane, as shown below in Figure 4. This causes a solvent, such as water, to pass through the membrane and leave behind dissolved solutes or contaminants.

Due to the one way flow design of RO units, pretreatment is often necessary to remove solids, organic matter, and potential scaling hazards. Scaling occurs when inorganic salts in the reject stream rise in concentration, due to less solvent present to dilute the system. As concentrations of contaminants rise, they approach their solubility limit. At the solubility limit, these dissolved particles and contaminants begin to precipitate out of solution. Scaling causes a reduction in membrane efficiency, since solids along the surface of the membrane will prevent water from passing through. Thus as concentrations rise, the amount of pressure needed to be applied rises as well.

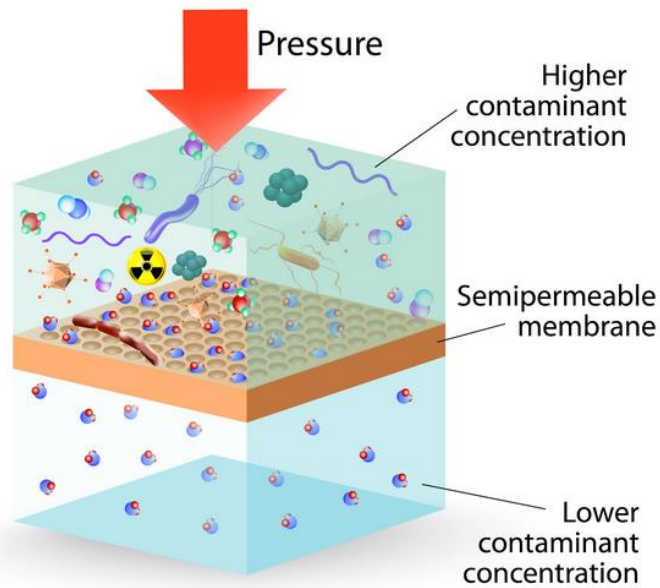

Figure 4: Graphic illustration of the reverse osmosis process

SANITARY EFFULENT RECOVERY FACILITY

SERF processes water through a combination of two treatment techniques: chemical coagulation and reverse osmosis. As of August 2018, SERF's process is modeled through the process flow diagram depicted in Figure 5 below. The main two components of the process are the two reactor tanks and the RO unit. The chemical coagulation process occurring in the reactor tanks serve as the pretreatment for the influent stream to be processed prior to being fed through the RO units. In the reactor tanks ferric chloride (FeCl_3), magnesium chloride (MgCl_2), and caustic/sodium hydroxide (NaOH) are mixed with the influent water stream. These chemicals react with the constituents in the water creating a floc to precipitate pollutants out of solution. Through the coagulation process a majority of the silica is removed with the precipitated floc. Since a majority of the silica is removed at this stage, silica scaling in the RO membranes becomes less of a concern. The RO units are capable of reducing the concentration of the constituents within the water to well below 1 mg/L (ppm). SERF is currently undergoing modifications to adjust flaws in the original SERF design, as well as improve the efficiency of their process.

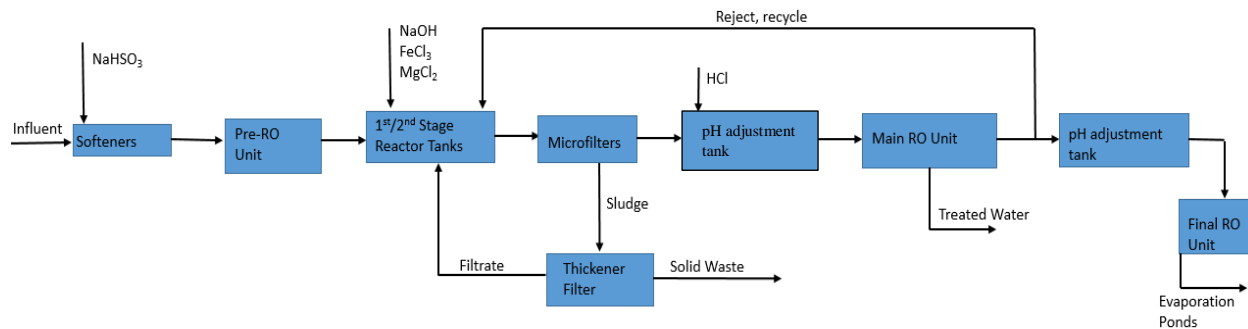

Figure 5: Flow diagram of SERF's operations prior to design modifications

The process outlined in Figure 5, has significant design flaws that effect SERF's ability to efficiently treat water. The purpose of the chemical coagulation process is to, promote a reaction with the constituents in the water to get the constituents to precipitate out of solution. It is important to note that the precipitate or floc that is produced is fragile. The mixing blades in the tanks are operating at a rate of 360 RPM inside a tank with baffles along the walls. The higher rotating blades alongside the baffles results in a highly turbulent environment, which can destroy the floc created by coagulation and leave the constituents dissolved in solution. Thus reducing the effectiveness of the coagulation process and sending water with higher silica concentration than expected to the RO units. Additionally, the reject recycle stream leaving the RO units is fed to the 2nd stage reactor tank. This means that water highly concentrated with contaminants that are trying to be removed are being re-introduced into the process stream. Contaminants within this stream are also not allowed to react for the entire residence time due to their injection point. This results in a large quantity of chemicals needed to be mixed into the

tanks in order to facilitate the reaction. In addition to this the feed lines for the chemicals initiating the coagulation process are sending chemicals to an inefficient location. Chemicals are being released at the bottom of the reactor tank, instead of at the top of the reactor tank. Therefore the reaction is initiated at the bottom of the tank as the water is processed into the second reactor tank. Thus the full residence time for the reaction isn't being recognized with the original SERF design. This has led the reaction to continue as the water enters the RO units, which causes fouling of the RO membranes.

The settling tank water flows into after the reactor tanks isn't designed as clarifiers. At SERF the generated solid waste or floc isn't directed towards the pump or extraction point. Therefore a portion of the tank is occupied by solid waste that will not be extracted through the pump. With a clarifier, the generated waste is directed towards a small extraction point. Lastly, SERF was designed and constructed without redundancy. Meaning that if a pump or any mechanical component were to fail, then SERF would be unable to treat water. This design flaw causes SERF to be unable to supply a continuous stream of treated water to the SCC.

SERF spends approximately \$1.5M~\$2M a year on chemicals in order to perform chemical coagulation. Which accounts for approximately half of their annual operating cost of \$3M. With the design modifications, depicted below in Figure 6, both the chemical consumption and operating cost are projected to decrease significantly. With the design modifications there is no longer a reject recycle stream leaving the RO units to the reactor tanks. This means that the quantity of chemicals needed to be mixed into the reactors will decrease. The modifications will also address issues such as the injection point for chemicals into the reactor tanks, and controls for better dosing of chemicals and monitoring of constituent in the tanks.

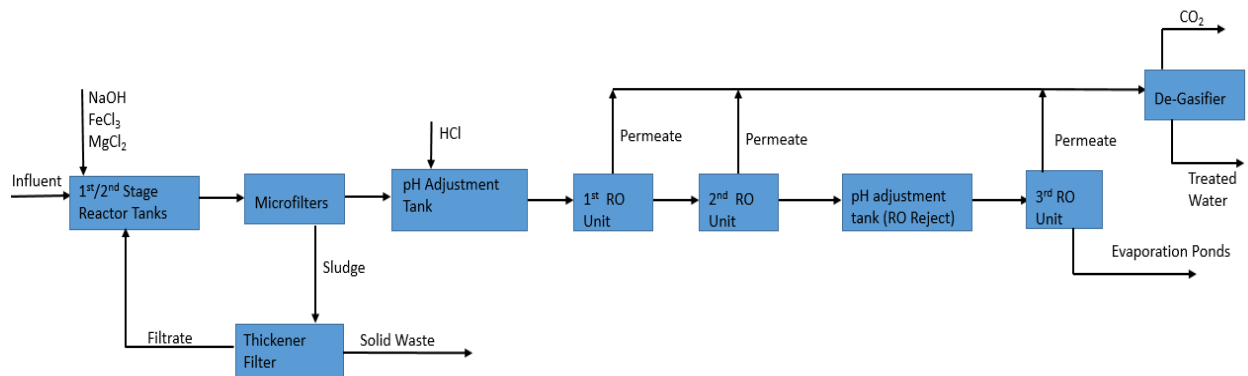

Figure 6: Flow diagram of future SERF operations with design modifications

At 100% capacity, SERF is capable of processing water at a rate of 217 GPM. Historically, SERF has operated at approximately 40~50% of its maximum capacity. This year however, SERF has been operating at approximately 70~80% of its maximum capacity due to increased demands from the SCC. Therefore SERF has been treating incoming water at a rate of 170 GPM since February of 2018. SERF chooses not to operate at 100% capacity due to excessive strain on the equipment. The facility can't sustain operating at 100% capacity for a long extended period of time, but can briefly. At 70~80% of maximum capacity, the staff is

constantly replacing and repairing equipment. Additionally SERF operates with a recovery percentage of approximately 90%, meaning that for every 100 gallons pumped to the facility 90 gallons of pure water is produced. With the modifications SERF at 100% capacity will still only be capable of processing water up to 217 GPM, however the recovery efficiency will raise from 90% to 97%. Resulting in 97 gallons of pure water for every 100 gallons of water pumped into the facility. Therefore, more water is usable for the cooling tower and less waste water is sent to the evaporating ponds. Phase 1 of the modifications have been completed, in which all electrical, plumbing, welding and supports have been installed and connected. Phase 2 is in progress, in which the staff is in the process of commissioning the new equipment and skids. Test are still being conducted to make sure that if pumps or valves are turned on or open that water will flow properly through the system. The recycle stream feeding RO reject to the 2nd reactor tank is still connected and hasn't been disconnected yet. After the modifications are completed, the concentrations of constituents in the water are expected to be at the levels outlined in the Table 1 below.

Table 1: Projected water quality concentrations for treated water leaving the RO units

Constituent	Treated Water Quality
pH	7.3
Silica (SiO ₂)	0.057 mg/L
PO ₄	0.038 mg/L
SO ₄	0.040 mg/L
Cl ⁻ (Chlorine ions)	11.299 mg/L
Fe	0.000 mg/L
PCB	0.000 mg/L
Total Hardness: Ca, Mg	0.029 mg/L
TDS	23.720 mg/L
CO ₂	0.215 mg/L
HCO ₃ ⁻	3.106 mg/L
NO ₃ ⁻	0.450 mg/L
H ⁺	0.000 mg/L
OH ⁻	0.002 mg/L
CO ₃ ²⁻	0.003 mg/L
Total Cations	8.724 mg/L
Total Anions	15.214 mg/L
Conductivity	11.300 μS

The water quality listed in the table indicate the concentration of the constituents leaving the RO units, not the constituent concentration of the water being sent to the SCC. Water being sent to the SCC is a mix of the clean effluent stream from the RO units and dirty effluent water from SWWS. The quality of the water currently produced by SERF is stated in Appendix A.

WATER QUALITY NEEDS

The following table list the water quality constraints placed upon SERF and the SCC. System limitations are defined as the limit at which adverse effects to the cooling towers and systems can occur, such as corrosion and scaling. Environmental limits are defined by Global Water Development Partners (GWDP), National Pollutant Discharge Elimination System (NPDES), and New Mexico Water Quality Standards. The listed environmental limits may be subject to change due to these values being pulled from the 2013 permitting report, and the limits are redefined every 5 years.

Operating Limitations		
Constituent	Environmental Limit	System Limit
pH	6.6-8.8	7.0-8.8
Total Hardness: Ca, Mg	N/A	300 mg/L
Fe	1 mg/L	1 mg/L
SiO ₂	N/A	120 mg/L*
SO ₄	600 mg/L	300 mg/L
TDS	1000 mg/L	N/A
Chlorides	250 mg/L	300 mg/L
PCB	640 mg/L	N/A
PO ₄	N/A	15 mg/L

Table 2: Compliance requirements and design constraint placed on water treated by SERF

*At a neutral pH, silica's solubility limit is approximately 120 mg/L. With the addition of a scaling inhibitor silica can remain dissolved in solution at concentrations up to 350 mg/L.

The following table list the filtered concentration levels needed to be achieved for the FSI. Using the stricter value or range given by the environmental permits and system operation guidelines, the following values were generated on the bases of running 8 COC. Operating at higher than 6 COC doesn't significantly reduce the amount of water being fed through the system. Therefore defining limits based on 8 COC will provide a safety margin in case of mechanical failures or unforeseen problems.

Constituent	Makeup Quality
pH	6.6-8.8
Total Hardness: Ca, Mg	37.500 mg/L
Fe	0.125 mg/L
SiO ₂	15.000 mg/L
SO ₄	37.500 mg/L
TDS	120.000 mg/L
Chlorides	31.250 mg/L
PCB	80.00 mg/L
PO ₄	1.875 mg/L

Table 3: Concentration limits to maintain environmental compliance and operate at 8 COC

Treatment Options

The 125 MGY of water demand equates to a need for 238 GPM of water leaving LANL's water treatment facility. Assuming a recovery rate of 90%, water will need to be supplied to the facility at a rate of 264 GPM. SERF at maximum capacity is only rated to handle 217 GPM of influent water, therefore will be unable to meet the demands of the new computing complex as well as the SCC. Since maximum capacity at SERF is unsustainable, SERF will likely continue to operate around 60~80% capacity. Meaning that approximately 100 GPM of water will still need to be treated by another facility, or potable water will need to be used to fill the gap. With the construction of a new treatment facility to be built alongside SERF, there are a few options for how the new facility should operate. Either replicate SERF's modified process, replace the current chemical pre-treatment process with an alternative water treatment technology, or operate without pre-treatment.

Option 1: Replicate SERF with design modification

With the SERF modifications the facility will continue to process 170 GPM of water, which equates to 165 GPM of treated water for cooling towers. In order to fulfill the remaining water quality needs for the FSI and SCC/, a new facility under the modifications would need to be rated to handle at least 150 GPM at maximum capacity. Similarly to SERF, the new facility would operate at 70% of its maximum capacity with a projected recovery of 97%. Resulting in 105 GPM of influent water and 102 GPM of treated water to be used by the cooling towers.

There are still lingering design flaws not addressed with SERF that should be addressed if a new facility is to mirror the general design of the modifications. The current pH adjustment process has a pH probe in the adjustment tank or right next to the adjustment chemicals. A proper set up would have a pH probe in the feed line into the adjustment tank, and an additional pH probe at the outlet of the tank. This setup would provide more accurate information for the chemical dosing needs. As stated in the SERF operations section, the speed of the mixing blades in the reactor tank as well as the lack of a clarifier hinders SERF's ability to precipitate and remove contaminants. Additionally, the electrical connections and plumbing should be redesigned. None of the electrical connections at SERF are marine grade, which is a problem due to the nature of the facility and the close proximity to water. SERF was designed with galvanized pipes, however over time water can aggressively corrode and rust the inside of these pipes. In addition to water corroding the pipes, the pipes were laid under concrete which also react to corrode them over time.

With the design of a new facility, redundancy and suppliers are crucial to the reliability of the treatment facility. To avoid having to supply potable water to the cooling towers, LANL's water treatment facilities need to be able to maintain a consistent supply of treated water. As stated in the SERF operations section, SERF was constructed and designed without mechanical or electrical redundancy. All the valves and controls at SERF are manual or pneumatically controlled. In order for pneumatic controls to work air pressure is needed. Currently the air pressure utilized for the pneumatic controls is supplied by one air compressor.

If the compressor were to break or go offline then the facility would lose functionality of the pneumatic controls as well as the ability to push water through the microfilters. Two air compressors should operate alongside each other, one as the primary air compressor and the other operating at a lower capacity. Since there's no electrical redundancy, SERF is at risk of ceasing operations during storms or power outages. The RO units could be operated manually, however without power, the pumps would be unable to send the treated water out towards the cooling towers. Lastly, when considering vendors or suppliers for equipment, local and/or domestic companies and manufactures should be prioritized. Currently SERF has to order replacement parts and equipment for the air compressor from Berlin. Thus causing shut downs ranging from 6~10 weeks. Due to a combination of waiting for replacement equipment to arrive, as well as back-up critical equipment not being stored on site.

The benefits of eliminating the recycle stream can be shown in Table 4 and Table 5 below. By not recycling highly concentrated pollutants back into the reactor tanks, the amount of chemicals needed for coagulation decrease drastically. The decrease in the amount of chemicals needed is highlighted by the second column, which shows how many gallons of chemicals are needed per kilogallon of water to be treated. The reduction of chemicals results in operation savings of approximately \$1.5M annually.

Table 4: Annual operating cost of chemical coagulation under original design

Original Design			
Chemical	Gallon Chemical/ Kilogallon Water Feed	\$/Gallon Chemical	Yearly Chemical Cost
MgCl ₂	2.000	5.749	\$909523.99
FeCl ₃	0.339	4.849	\$130030.05
NaOH (25%)	4.976	3.742	\$1472909.32
HCl	0.269	3.545	\$75432.83
		Total	\$2587896.20

Table 5: Annual operating cost of chemical coagulation under modified design

Modified Design			
Chemical	Gallon Chemical/ Kilogallon Water Feed	\$/Gallon Chemical	Yearly Chemical Cost
MgCl ₂	0.858	5.749	\$390185.79
FeCl ₃	0.051	4.849	\$19562.04
NaOH (25%)	1.590	3.742	\$470644.26
HCl	0.626	3.545	\$175542.56
		Total	\$1055934.65

If a transition is made from a NaOH with a weight percentage of 25% to 50%, additional operating savings could be achieved. The cost of NaOH at 25 weight percent is \$1,196.80 per tote or 320 gallons. NaOH with a 50 weight percent cost \$1,211.76 per tote or 320 gallons. NaOH at 25 weight percent supplies SERF with 1,206 grams of caustic per gallon, while NaOH at 50 weight percent supplies SERF with 2,890 grams of caustic per gallon. Therefore over twice the amount of usable chemical is supplied for an extra \$15 per 320 gallons purchased. At an influent rate of 150 GPM, the cost of caustic drops from \$470,644 per year to \$238,101. Reducing chemical purchasing cost by an additional \$230,000. However, this change will come with a re-evaluation of the hazard classification of SERF and the new facility. Currently SERF is a low chemical hazard facility, due to the low concentration and strength of the chemicals used. The switch may raise the hazard level of the facility to a moderate chemical hazard.

Option 2: Replace chemical pre-treatment process with an alternative pre-treatment

Option two follows the same modified SERF design as outlined in Option one and discussed in the SERF description section of the report. However, this option focuses on replacing the chemical coagulation process with an alternative treatment method. The chemical coagulation process receives a significant portion of SERF's operating budget. The cost of treating water under the same conditions come out to \$32.72 per kilogallon of influent water into a facility without the modifications and \$13.35 per kilogallon for a facility with the modification. Alternative pre-treatment could provide the same level of treatment without the need to purchase chemicals. Electrocoagulation has been investigated and used industrially for the removal of silica and other contaminants from water.

Electrocoagulation has advanced significantly since its conception due to the cost of electricity decreasing. WaterTectonics, Water Vision, Samco Technologies, and Powell Water are a few companies that specialize and construct EC units. These companies sell units ranging from 10 GPM to 1,000 GPM and greater. Through discussion with a vendor at WaterTectonics, the make-up of the water play a huge role in determining the system design of the EC reactor. The make-up affects the size of electrodes, dosing requirements, as well as the magnitude of the electric current to be passed through the system. All these factors come into play when considering the operating cost of an EC unit, and how it'll be maintained. On average an EC unit cost \$1.50 per kilogallon of influent water, but can cost as low as \$0.50 per kilogallon of influent water to operate. Under the same flow conditions analyzed in Option 1, the cost to treat 152 GPM of water would result in an annual operating cost of \$11, 9758. Potentially saving an additional million dollars a year on operating the pre-treatment portion of the plant. WaterTectonics has also conducted an in-depth feasibility study, summarized in Appendix C, on the various water treatment techniques, and their ability to treat the silica in the water in Longview, Washington.

Some modern EC systems have addressed the problems associated with passivation and the corrosion of the anodes. Water Vision has developed proprietary thin cell electrodes that aren't consumed like they would in a traditional EC system. Their system requires a constant supply of aluminum, which is placed in between the electrodes. This process takes a

few minutes with little impact to the continuous flow or operation of the system. Powell Water's EC systems are designed to take AC current, as opposed to the traditional DC current. AC current has been shown through benchtop experimentation to preserve the electrodes and reduce the effect of passivation. Overtime AC current consumes less of the electrodes, thus prolonging the lifespan of the system.

This option would require a pilot study to be conducted prior to a full commitment to the system. Benchtop experimentation must be done to understand how the county water or SWWS water would interact with the electrodes, and obtain the dosing requirements to meet LANL's water quality needs. The pilot study would also generate data in order to plan for the electrical and power requirements of the system. If an EC system were to be chosen then electrical redundancy would be crucial to the operational capability and reliability of the treatment facility. In the event of a power outage or heavy storm, the entire plant would be left inoperable except for the RO membranes. Since the pumps need power to get treated water out of the plant and the EC reactors need power to establish a current through the electrodes, data from the pilot study would give a specific operating cost and state how much the cost differs from the average \$1.50 per kilogallon of influent water.

Option 3: Remove pre-treatment

With this option the cost associated with chemical coagulation process would be removed. Resulting in \$2M in operation savings since chemicals aren't required for pre-treatment. Therefore, the main operational component for the removal of silica would be the RO units. A scaling inhibitor would have to be used similarly to what is used currently at SERF, since silica leaving the final RO stage has a silica concentration of approximately 300~400 mg/L. Samco Technologies has investigated the requirements and feasibility of such a system, and reported back with the following design. The RO unit was sized to produce 250 GPM usable water, however the RO recovery was 50%. This equates to 262,800,000 gallons of supply water needed to obtain 131.4 million gallons of cooling water. With this setup an additional 9 million gallons of potable water would still be required to fulfill the estimated 140 million gallons required by the scaled down operations of the SCC and FSI. The low recovery rate is due to the high concentration of silica in the influent water. Specifics on operating cost are dependent on the level of automation required and type of RO membrane used. A portion of the savings associated with no longer needed large quantities of chemicals would be redirected toward the maintenance, cleaning, and purchasing of new RO membranes. The lifespan of an RO membrane can span from 9 months to 3 years and cost approximately \$500 each. It cost SERF \$175 to clean each membrane, so that they may be reused once they have fouled to a certain degree.

Due to the low recovery rate a large waste stream would be generated through the process. SERF prior to the modifications has experienced occasional struggles with managing RO reject water, which is sent to evaporation ponds. Currently there are 5 evaporation ponds that collect the RO reject water. Depending on the conductivity of the water, time of year, or ambient weather conditions the rate of evaporation may or may not be greater than the rate at which water is directed toward the ponds. In the event that the ponds become full, water must be pumped out and trucked away to another facility. It cost approximately \$350,000 a year to truck water away

due to ponds reaching their limit. With this option a significant investment must be made to construct new ponds to handle the 131,400,000 gallons of waste water generated yearly.

Estimated Cost

The following operating budgets were estimated based off of scaling SERF’s FY 17 operation budget, in which SERF operated at 40% capacity. Equation 1 below was used to calculate the total operating cost based off the options. Chemical and alternative pretreatment cost were calculated based on the influent demand required by SERF and new facility. The remaining operating cost were approximated by adding the remaining SERF budget not spent on chemicals to the product of the portion of SERF’s budget not spent on chemicals by the percentage increase in pre-treatment cost divided by 2. The cost of pursuing option 3 was excluded due to infeasibility of the system requirements, and variable waste stream cost. Operational savings of option 3 are transferred to capital investment in construction. Removal of liquid waste was neglected from all cost, since additional evaporating ponds would need to be constructed.

Operating Cost

$$= 70\% \text{ Pretreatment} + \text{FY17 nonchemical cost} + \text{FY17 nonchemical cost} \\ * \left(1 - \frac{70\% \text{ capacity pretreatment}}{40\% \text{ capacity pretreatment}} \right) * .5$$

Equation 1: Formula used to approximate total operating cost

Table 6: Estimated cost to operate two facilities under SERF’s original design

Unmodified SERF (70% max capacity, 152 GPM influent)			
Chemical	Gallon Chemical/ Kilogallon Water Feed	\$/Gallon Chemical	Yearly Chemical Cost
MgCl ₂	2.000	5.749	\$909523.99
FeCl ₃	0.339	4.849	\$130030.05
NaOH (25%)	4.976	3.742	\$1472909.32
HCl	0.269	3.545	\$75432.83
Total			\$2587896.20
Operating Cost			\$5481844.30
Replicate (70% max capacity, 105 GPM influent)			
Chemical	Gallon Chemical/ Kilogallon Water Feed	\$/Gallon Chemical	Yearly Chemical Cost
MgCl ₂	2.000	5.749	\$634551.62
FeCl ₃	0.339	4.849	\$90718.64
NaOH (25%)	4.976	3.742	\$1027611.16
HCl	0.269	3.545	\$52628.50
Total			\$1805508.97
Operating Cost			\$4308263.46
Grand Total			\$9790107.76

Table 7: Estimated cost to operate two facilities under SERF's modified design

Modified SERF (70% max capacity, 152 GPM influent)			
Chemical	Gallon Chemical/ Kilogallon Water Feed	\$/Gallon Chemical	Yearly Chemical Cost
MgCl ₂	0.858	5.749	\$393815.43
FeCl ₃	0.051	4.849	\$19744.02
NaOH (25%)	1.500	3.742	\$475022.34
HCl	0.626	3.545	\$177175.31
Total			\$1065757.30
Operating Cost			\$2131514.30
Replicate (70% max capacity, 105 GPM influent)			
Chemical	Gallon Chemical/ Kilogallon Water Feed	\$/Gallon Chemical	Yearly Chemical Cost
MgCl ₂	0.858	5.749	\$272222.65
FeCl ₃	0.051	4.849	\$13647.94
NaOH (25%)	1.500	3.742	\$328356.46
HCl	0.626	3.545	\$122471.55
Total			\$736698.60
Operating Cost			\$1905047.90
Grand Total			\$4036562.20

Table 8: Estimated cost to operate two facilities under SERF's modified design and caustic transition

Modified SERF (70% max capacity, 152 GPM influent)			
Chemical	Gallon Chemical/ Kilogallon Water Feed	\$/Gallon Chemical	Yearly Chemical Cost
MgCl ₂	0.858	5.749	\$393815.43
FeCl ₃	0.051	4.849	\$19744.02
NaOH (50%)	0.663	4.540	\$240315.90
HCl	0.626	3.545	\$177175.31
Total			\$831050.86
Operating Cost			\$2046576.29
Replicate (70% max capacity, 105 GPM influent)			
Chemical	Gallon Chemical/ Kilogallon Water Feed	\$/Gallon Chemical	Yearly Chemical Cost
MgCl ₂	0.858	5.749	\$272222.65
FeCl ₃	0.051	4.849	\$13647.94
NaOH (50%)	0.663	4.540	\$166116.98
HCl	0.626	3.545	\$122471.55
Total			\$574459.12
Operating Cost			\$1661688.68
Grand Total			\$3708264.97

Table 9: Estimated cost to operate SERF under the modified design and new facility with EC

Modified SERF (70% max capacity, 152 GPM influent)			
Chemical	Gallon Chemical/ Kilogallon Water Feed	\$/Gallon Chemical	Yearly Chemical Cost
MgCl ₂	0.858	5.749	\$393815.43
FeCl ₃	0.051	4.849	\$19744.02
NaOH (25%)	1.500	3.742	\$475022.34
HCl	0.626	3.545	\$177175.31
Total			\$1065757.30
Operating Cost			\$2131514.30
New Facility with EC pretreatment (70% max capacity, 105 GPM influent)			
Chemical	\$/kilogallon influent	Yearly kilogallon feed	Cost
Electrocoagulation	\$1.5	55,200	\$82800.00
Operating Cost			\$1082800.00*
Grand Total			\$3214314.30

*Assumed that the modification and specified operating flow rate cut the scaled \$1.6 million by \$600,000. Therefore adding an additional \$1 million to annual operating cost.

Table 10: Estimated cost to operate SERF under the modified design with caustic transition, and new facility with EC

Modified SERF (70% max capacity, 152 GPM influent)			
Chemical	Gallon Chemical/ Kilogallon Water Feed	\$/Gallon Chemical	Yearly Chemical Cost
MgCl ₂	0.858	5.749	\$393815.43
FeCl ₃	0.051	4.849	\$19744.02
NaOH (50%)	0.663	4.540	\$240315.90
HCl	0.626	3.545	\$177175.31
Total			\$831050.86
Operating Cost			\$2046576.29
New Facility with EC pretreatment (70% max capacity, 105 GPM influent)			
Chemical	\$/kilogallon influent	Yearly kilogallon feed	Yearly Chemical Cost
Electrocoagulation	\$1.5	55,200	\$82800.00
Operating Cost			\$1082800.00*
Grand Total			\$3129376.29

*Assumed that the modification and specified operating flow rate cut the scaled \$1.6 million by \$600,000. Therefore adding an additional \$1 million to annual operating cost.

RECOMMENDED COURSE OF ACTION

Between the three options, option two is the recommended course of action to be pursued by the lab. The bulk of SERF's operating cost is tied to the chemical coagulation process at the front end of the plant. The cost of pretreatment could be reduced by a factor of 10 with the replacement of the current chemical coagulation process with an electrocoagulation process. Although Option 1 maintains a chemical coagulation pre-treatment process, it does outline necessary corrections to design flaws with SERF's setup overall. The lessons learned with SERF's design flaws should be used as a basis for future plant design. Based on the result of the pilot study to be conducted by an electrocoagulation vendor, influent water should be treated by electrocoagulation instead of chemical coagulation. If the results come back negative and the power requirements of the system are too large, then option 1 should be followed with a hazard evaluation conducted for exchanging NaOH from 25 weight percent to 50 weight percent.

Results and designs of the pilot study conducted by an EC vendor should be reviewed and checked by a LANL chemical or process engineer for validity such as Paul Parker. The original designers of SERF didn't do their due diligence, and check their calculations before construction. Resulting in a system in which the reactor tanks weren't sized correctly for the volume of water needed to be fed through the system. As a result, the chemicals mixed with water are not allowed to react for the entire residence time necessary for the reaction. The reaction called for a residence time of 45 minutes, however the system has water flowing out in 15 minutes. In addition to checking the calculation and engineering behind the design, the layout of the design should be reviewed by experienced operators to verify the functionality of the design. This is to ensure that the placement of equipment, material selected, and piping won't hinder the functionality of the facility or ability of operators.

Option three isn't recommended due to the substantial reject waste stream generated as a byproduct. Money saved through lowering operating cost would be spent up front on the construction and management of evaporating ponds. In order to increase the recovery percentage of the RO units, a pre-treatment process is required. Without such a process the high silica content of the water will foul and destroy the membranes too quickly, causing constant cleaning and replacement of the membranes. In addition to the large reject waste stream generated, the process would require a significant quantity of water. Combining the county non-potable water and SWWS water would only result in approximately 300,000,000 gallons of water per year, which can potentially meet the systems requirement. This quantity is variable as the water demands from the county fluctuate yearly. Therefore LANL may not have the water available to operate a system without pretreatment, and doesn't have the infrastructure in place to handle the waste generated by a process without a pre-treatment.

It should be noted that the operators of SERF and engineers at the Utilities office are working on alternative process that will also eliminate the current chemical coagulation process. The solution looked upon by the SERF staff and engineers involves a combination of an additional RO unit and ion exchange. After the results of the study, a discussion should be held with the SERF operators and engineers to discuss any potential findings.

Appendix

- A. SWWS Effluent Water Quality Data
- B. County Water Quality Data
- C. Case Study- City of Longview, WA
- D. Electrocoagulation Vendor Contact

Appendix A: SWWS Effluent Water Quality Data

Table 1: Average concentrations of key constituents found in water leaving SWWS

Constituent	Average
Conductivity	660.00 μ S
pH	7.55
Total Hardness	35.33 mg/L
Hardness: Ca	23.67 mg/L
PO ₄	14.85 mg/L
SiO ₂	98.67 mg/L
Chlorides	81.43 mg/L

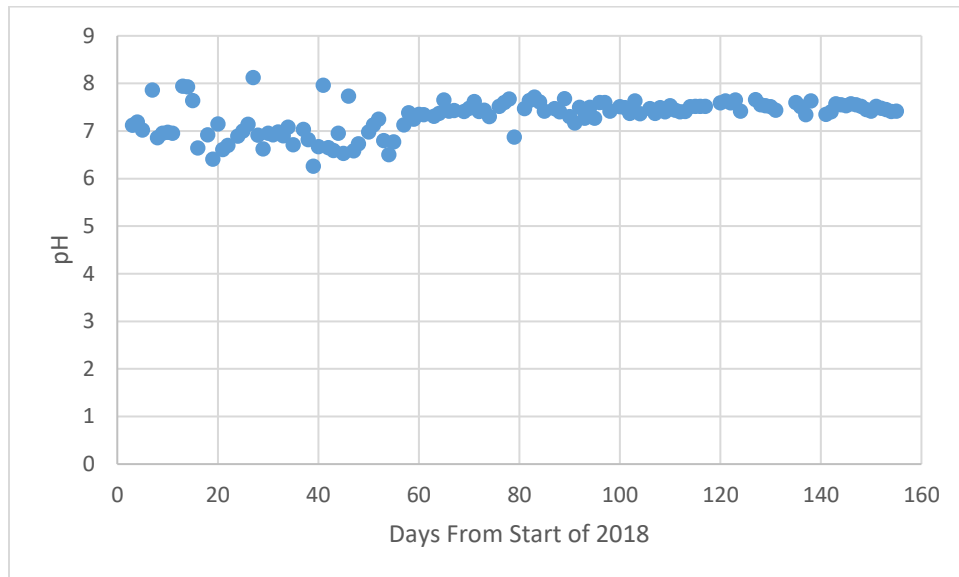

Figure 1: Day by day pH level of the effluent water leaving SWWS from January 1, 2018 to June 16, 2018

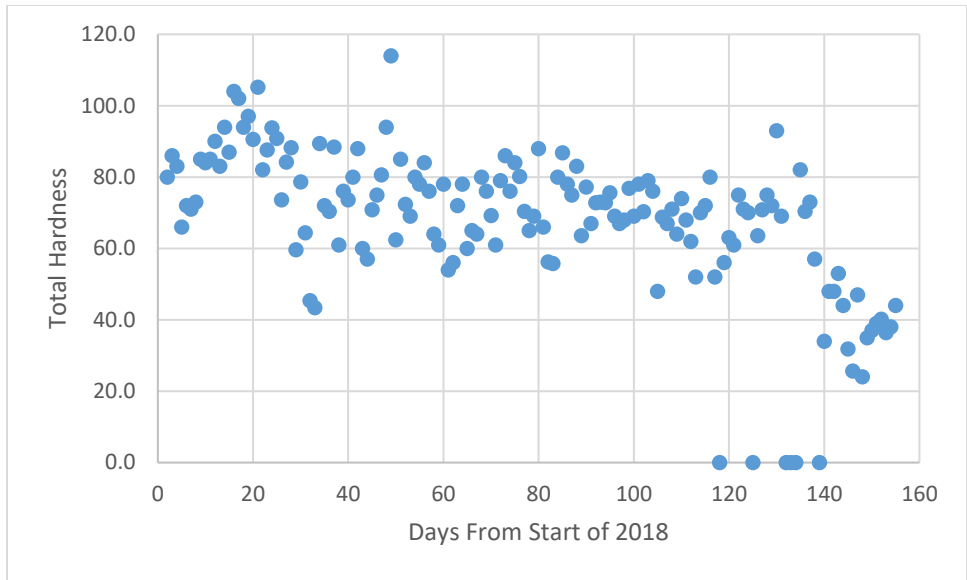

Figure 2: Day by day total hardness in the effluent water leaving SWWS from January 1, 2018 to June 16, 2018

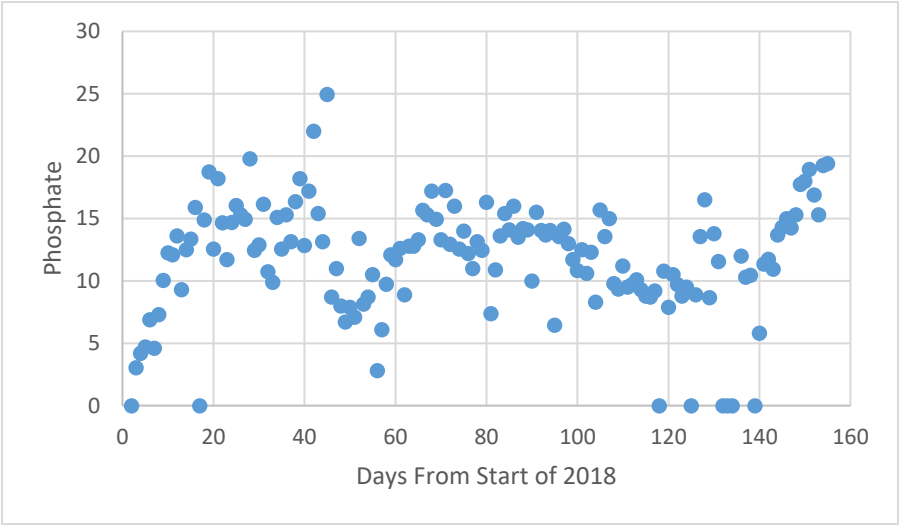

Figure 3: Day by day concentration of phosphate in the effluent water leaving SWWS from January 1, 2018 to June 16, 2018

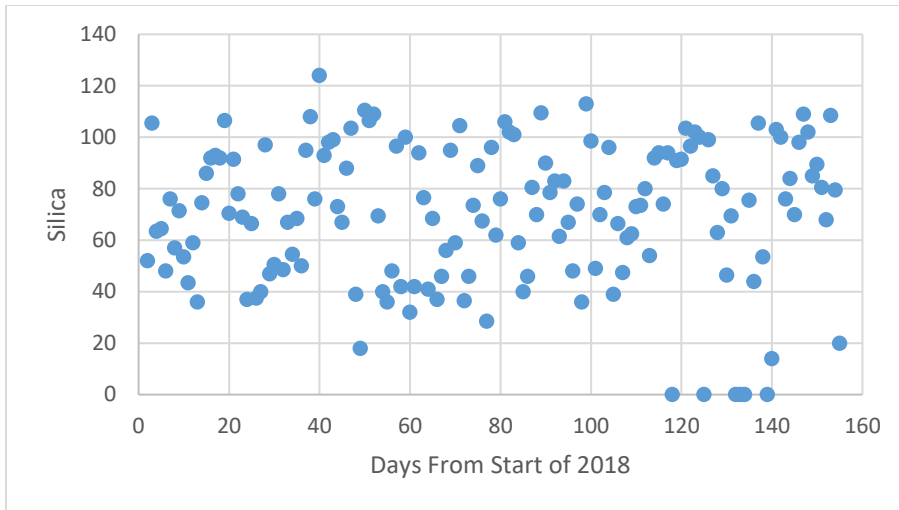

Figure 4: Day by day concentration of silica in the effluent water leaving SWWS from January 1, 2018 to June 16, 2018

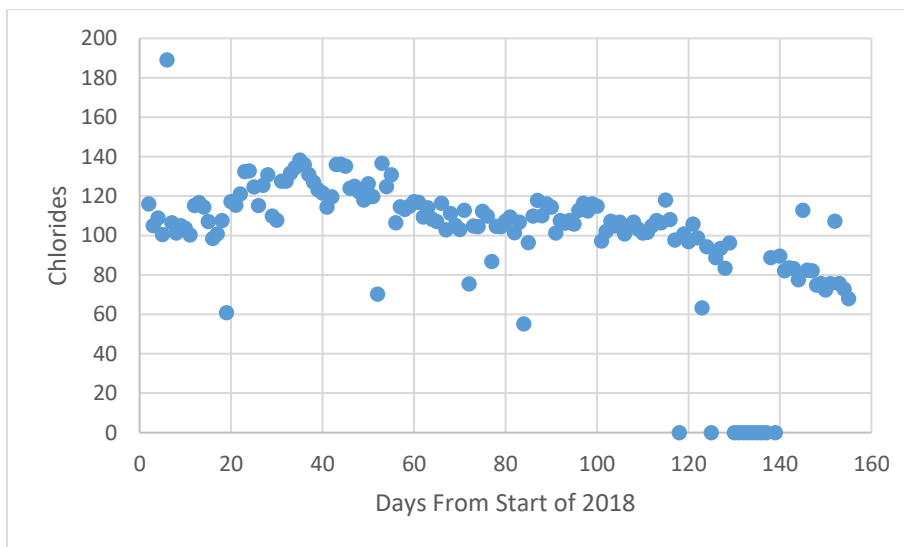

Figure 5: Day by day concentration of chlorides in the effluent water leaving SWWS from January 1, 2018 to June 16, 2018

Appendix B: County Water Quality Data

Table 1: Quality of LAC water tested on two separate occasion for key constituents

Test 1	
Constituent	Quality
Conductivity	463.00 μ S
pH	7.42
Total Hardness	24.00mg/L
Hardness: Ca	14.00 mg/L
PO ₄	15.90 mg/L
SiO ₂	72.00 mg/L
Chlorides	56.00 mg/L
Test 2	
Constituent	Quality
Conductivity	494.70 μ S
pH	7.05
Total Hardness	38.00 mg/L
Hardness: Ca	28.00 mg/L
PO ₄	10.10 mg/L
SiO ₂	84.00 mg/L
Chlorides	85.60 mg/L
Iron	0.01 mg/L

Appendix C: Case Study- City of Longview, WA

In 2017, the City of Longview contracted WaterTectonics to conduct a feasibility study to find an effective method to treat silica in the municipal water. In addition to the treatment technologies addressed within this report, WaterTectonics addressed lime softening. Lime softening works by constituents adsorbing onto magnesium precipitates, similarly to an inorganic chemical coagulation process. This technology was neglected in the report due to its inability to remove large quantities of silica. At the end of the study, electrocoagulation and precipitation were found to be the two best option for water treatment. The recommendation from WaterTectonics to the city was for them to pursue precipitation, which is referred to as chemical coagulation in this study. This is due to the new nature of the electrocoagulation technology, and the established compliance regulations and track record for precipitation (chemical coagulation). It was also recommended to perform a pilot study for and electrocoagulation system, since it's lower operating cost is a significant advantage for the system. The following tables and figures summarize the results of WaterTectonics study, as well as show potential process flow designs.

It should be noted that the treatment designs developed by WaterTectonics are each treatment technology acting independent. Therefore, a combined process such as SERF wasn't assed in their study. Also the City of Longview didn't end up pursuing water treatment for their silica water. The results still effectively compare and contrast the effectiveness and ability of each treatment technology.

Table 1: Breakdown of capital cost for each water treatment technology

Treatment Alternative	Electro-coagulation	Precipitation	Lime Softening	Ion Exchange	Reverse Osmosis
Preloading	500,000	500,000	500,000	500,000	500,000
Well Pump Modifications				700,000	
Electrocoagulation	5,665,000*				
Rapid Mix	550,000	550,000			
Flocculation	698,000	698,000			
Clarifier	2,317,000	2,317,000			
Chemical Feed		905,000	1,792,000		301,000
Ion Exchange				9,110,000	
Solids Contact Clarifier			1,702,000		
Pump Station	777,000	777,000	777,000		
Reverse Osmosis/Pumps System					14,661,000
Sludge Thickener	844,000	1,147,000	1,409,000		
Dewatering	4,226,000	4,320,000	4,691,000		
Outfall, Transmission					393,000
Subtotal	15,577,000	11,214,000	10,871,000	10,310,000	15,855,000
Contractor Markups (18%)	2,804,000	2,019,000	1,957,000	1,856,000	2,854,000
Contingency (25%)	3,894,000	2,804,000	2,718,000	2,578,000	3,964,000
Tax (8.1%)	1,262,000	908,000	881,000	835,000	1,284,000
Construction Subtotal	23,537,000	16,945,000	16,427,000	15,579,000	23,957,000
Location Adjustment Cost (98.1% of Construction Subtotal)	23,090,000	16,623,000	16,115,000	15,283,000	23,502,000
Design, SDC, Start-up (20%)	4,618,000	3,325,000	3,223,000	3,057,000	4,700,000
Total	\$27,708,000	\$19,948,000	\$19,338,000	\$18,340,000	\$28,202,000

Table 2: Breakdown for capital cost for an electrocoagulation process

Cost Item	Cost Estimate*
Excavation, Foundations and Site-work	\$12,000
Concrete for foundations and floors	92,000
Masonry (CMU) Building	780,000
Electrocoagulation Cells and Power Supplies (mid-point of high and low estimate provided by WaterTectonics)	2,650,000
EC Cells and Power Supplies Installation (25%)	663,000
Instrumentation and Control	280,000
Conveying Systems (Crane)	4,000
Mechanical	620,000
Electrical MCC Panels	286,000
Allowance for Miscellaneous items	278,000
Unit Process Total	\$5,665,000

Table 3: Breakdown for chemical cost requirements for each water treatment technology

Chemical Name	Cost per dry ton		Electro-coagulation	Precipitation	Lime Softening	Ion Exchange	Reverse Osmosis
Sodium Aluminate, as Al	\$1,692	Dose, mg/L		40			
		Cost per Yr		\$618,000			
Sulfuric Acid	\$392	Dose, mg/L		98			20
		Cost per Yr		\$507,000			\$151,000
Sodium Hypochlorite	\$2,213	Dose, mg/L					2.5
		Cost per Yr					\$107,000
Carbon Dioxide	\$59	Dose, mg/L			80		
		Cost per Yr			\$70,000		
Sodium Hydroxide	\$1,226	Dose, mg/L				113	25
		Cost per Yr				\$2,671,000	\$591,000
Lime, Hydrated	\$331	Dose, mg/L			80		
		Cost per Yr			\$510,000		
Soda Ash	\$298	Dose, mg/L			50		
		Cost per Yr			\$287,000		
Magnesium Chloride	\$845	Dose, mg/L			199		
		Cost per Yr			\$3,241,000		
Sodium Chloride	\$110	Dose, mg/L				133	
		Cost per Yr				\$282,000	
Sodium Bisulfite	\$1,090	Dose, mg/L					2.5
		Cost per Yr					\$53,000
Total Chemical Cost Per Year (2017)			\$0	\$ 1,125,000	\$1,125,000	\$4,108,000	\$2,953,000

Table 4: Breakdown of operation and maintenance requirements for each water treatment technology

Alternative	Electro-coagulation	Precipitation	Lime Softening	Ion Exchange	Reverse Osmosis
Power Cost	\$159,000	\$1,000	\$2,000	\$2,000	\$33,000
Labor Cost	108,000	108,000	108,000	108,000	108,000
Chemical Cost	-	1,125,000	4,108,000	2,953,000	902,000
Consumables Cost	577,000	-	-	-	440,000
Residuals Disposal Cost	59,000	77,000	105,000	255,500	
Total Annual O&M Cost	\$903,000	\$1,311,000	\$4,323,000	\$3,319,000	\$1,483,000

Table 5: Breakdown of how each technology was accessed and evaluated

No.	Evaluation Criteria	Weighting Factor
1	Environment	8%
	a. Chemical use	2%
	b. Waste streams, solids handling, disposal methods (Columbia River outfall)	4%
	c. Resource waste - water use/inefficiency (RO), electricity (double pumping), carbon footprint	2%
2	Economic	27%
	a. Capital Cost	8%
	b. O&M Cost	8%
	c. Rate impacts (ability to fund)	11%
3	WQ Aesthetics/Health	35%
	a. Silica reduction	25%
	b. Hardness reduction	5%
	c. Secondary benefit or detriment (chloramine removal vs. mineral stripping)	5%
4	Technical	30%
	a. Operability & Reliability (proven technology)	10%
	b. Safety	5%
	c. Distribution system impacts	5%
	d. Ability to add WTP and/or silica removal capacity; Wellfield encroachment	10%

Table 6: Grades given to each water treatment technology for each of the evaluation criteria. Ranking system has 5 as the best/great, and 1 as the worst/poor

No.	Evaluation Criteria	Weighting Factor	Electrocoagulation	Precipitation	Lime Softening	Ion Exchange	Reverse Osmosis
1	Environment	8%					
	a. Chemical use	2%	5	3	2	2	3
	b. Waste streams, solids handling, disposal methods (Columbia River outfall)	4%	4	4	2	2	1
	c. Resource waste - water use/inefficiency (RO), electricity (double pumping), carbon footprint	2%	4	4	2	3	1
2	Economic	27%					
	a. Capital Cost	8%	3	4	4	5	2
	b. O&M Cost	8%	5	4	1	2	1
	c. Rate impacts (ability to fund)	11%	4	4	1	2	3
3	WQ Aesthetics/Health	35%					
	a. Silica reduction	25%	5	5	2	2	5
	b. Hardness reduction	5%	1	1	3	4	4
	c. Secondary benefit or detriment (organic nitrogen removal vs. mineral stripping)	5%	3	3	4	1	4
4	Technical	30%					
	a. Operability & Reliability (proven technology)	10%	2	5	3	3	3
	b. Safety	5%	4	3	3	2	3
	c. Distribution system impacts	5%	3	3	4	1	4
	d. Ability to add WTP and/or silica removal capacity; Wellfield encroachment impact	10%	4	4	3	4	3

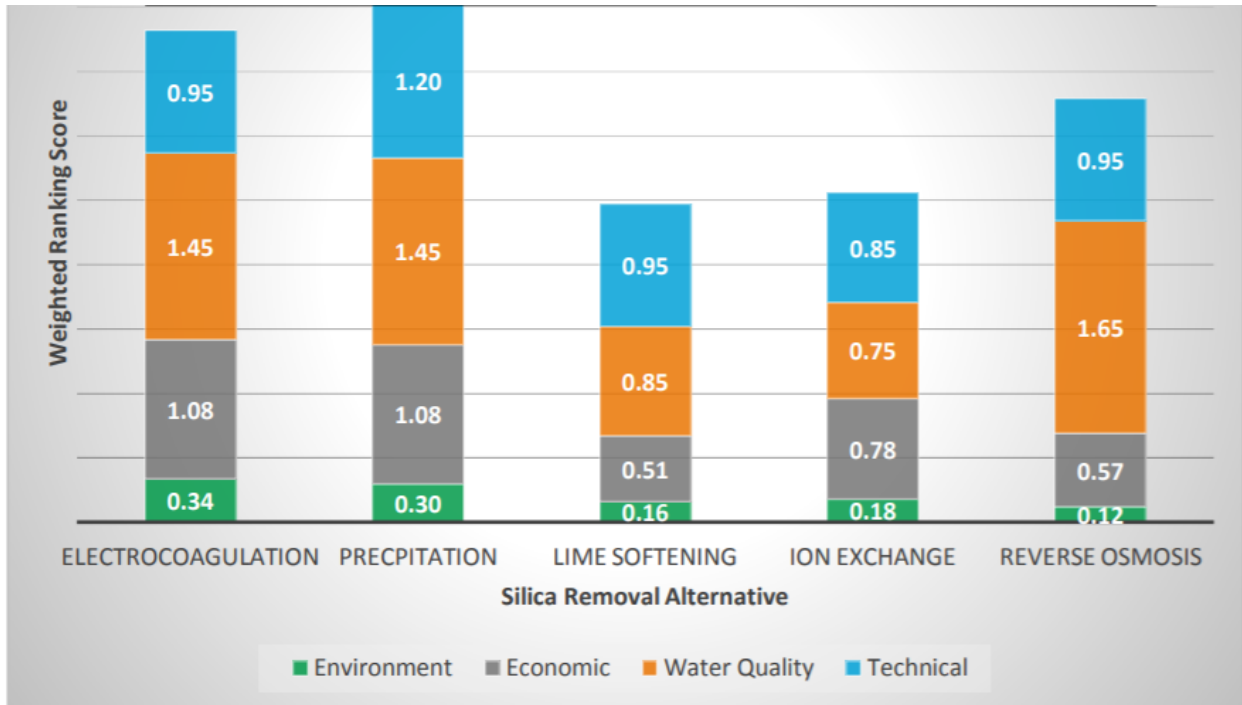

Figure 1: Bar graph of the evaluation criteria results

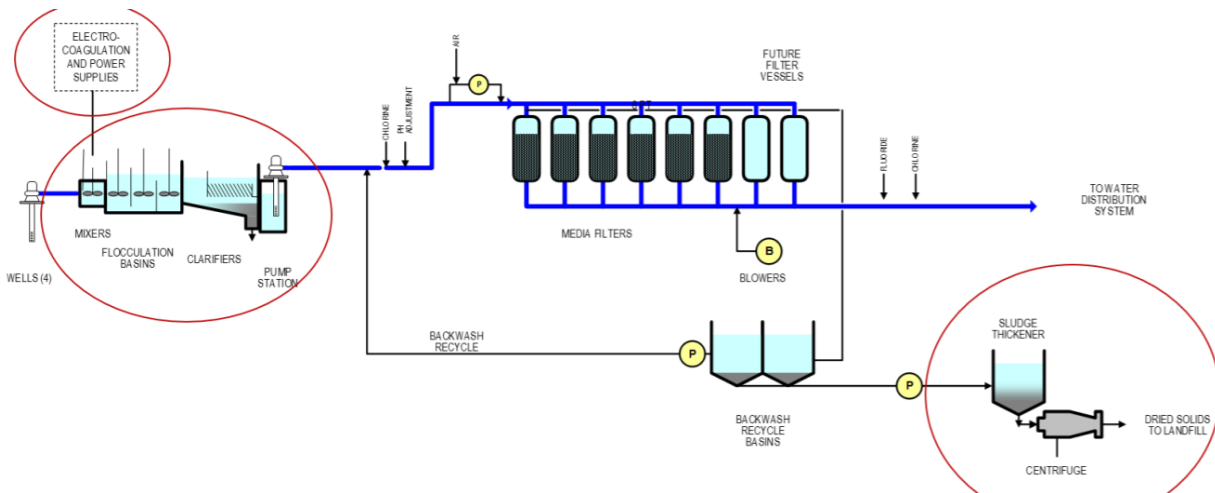

Figure 2: Potential process flow design for an electrocoagulation water treatment system

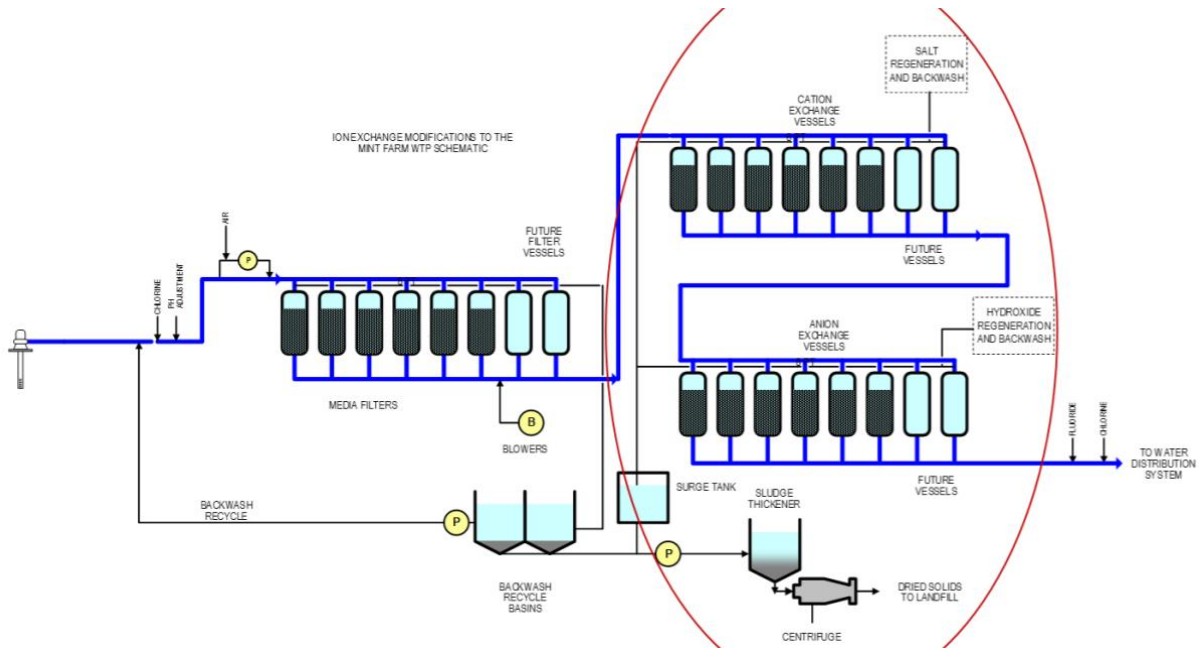

Figure 3: Potential process flow design for an ion exchange water treatment system

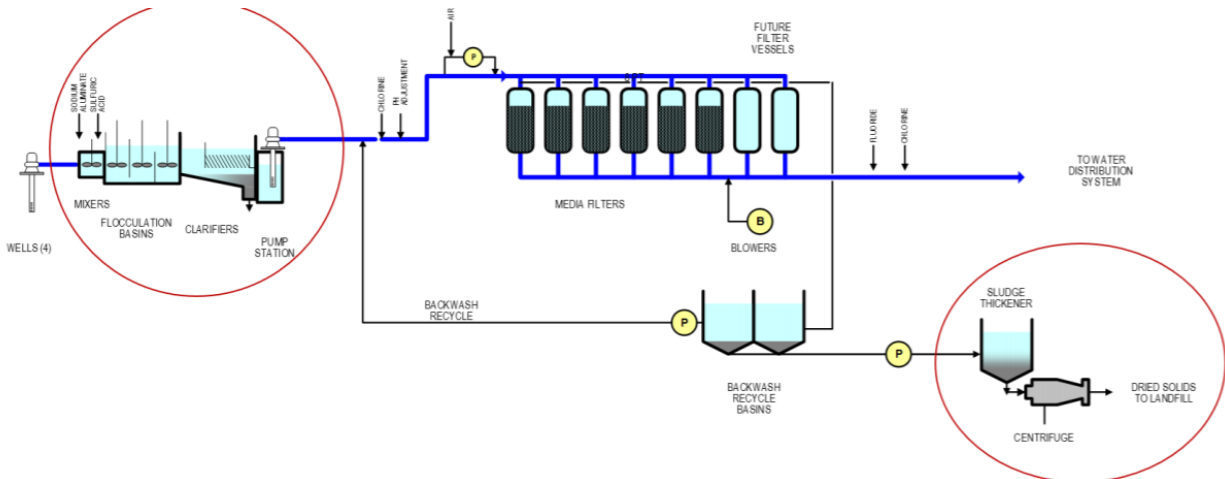

Figure 4: Potential process flow design for a chemical coagulation water treatment system

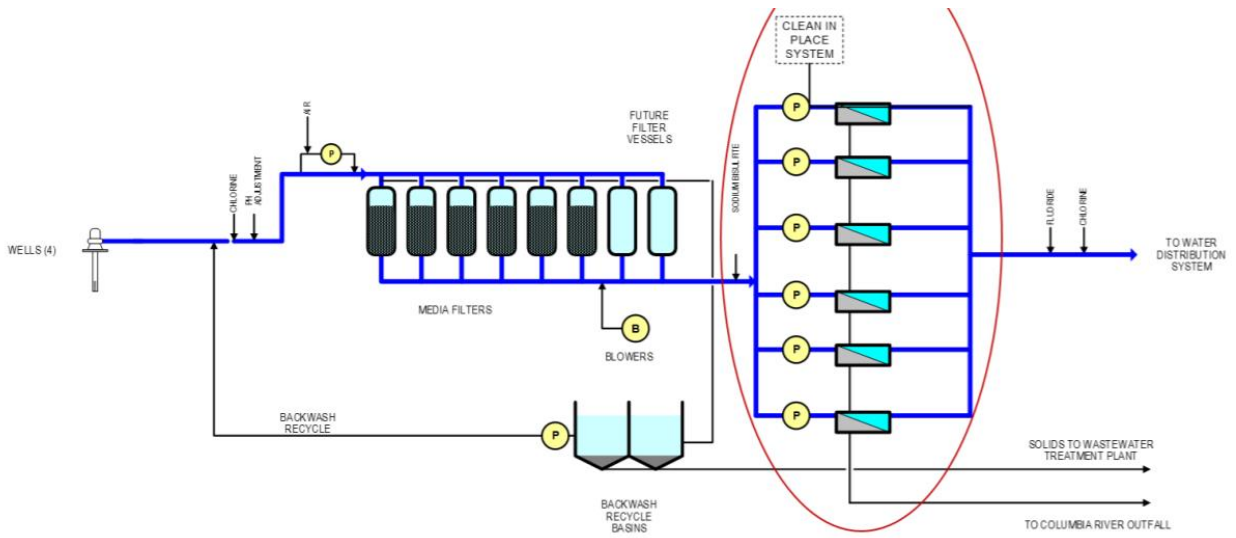

Figure 5: Potential process flow design for a reverse osmosis water treatment system

Appendix D: Electrocoagulation Vendor Contact

WaterTectonics

Location: 6300 Merrill Creek Parkway, Suite C-100, Everett, WA 98203

Name: TJ Mothersbaugh

Email: tj.mothersbaugh@watertectonics.com

Phone Number (Office): 425-312-6274

Phone Number (Cell): 206-947-5950

Product: WaveIonics

Water Vision

Location: 532 Stonegate Drive, Suite 100 Katy, TX 77494

Name: Jason Kirk

Email: jkirk@watervisioninc.com

Phone Number (Office): 281-601-1444

Phone Number (Cell): 832-266-9344

Product: Thin Cell EC

Samco Technologis

Location: One River Rock Drive, PO Box 1047, Buffalo, NY

Name: Bryan J. Woodruff

Email: woodruffb@samcotech.com

Phone Number (Office): 716-743-9000

Phone Number (Cell): 716-348-3378

Product: Electrodeionization (EDI)

Powell Water

Location: 19331 E Tufts Cir, Centennial, CO 80015

Phone Number (Office): 303-627-0320

Email: info@powellwater.com ; sales@powellwater.com

Product: AC Electrocoagulation systems